

## Common Terminal Block (screwless type)

### ■ Features

- Screwless push-in type for simple and easy connection
- No jumper bars required due to built-in common PCB
- For use as power supply expansion terminals
- Slim and compact design with 5mm terminal pitch
- 2 mounting methods (DIN rail, screw mount)

⚠ Please read "Safety Considerations" in instruction manual before using.



### ■ Ordering Information

Model	Item	Terminal type	The number of terminal	Common type
ACL-20L	Common terminal block	Screwless	20	Left-Right common
ACL-20T				Up-Down common
ACL-40L			40	Left-Right common
ACL-40T				Up-Down common
ACL-50L			50	Left-Right common
ACL-50T				Up-Down common

### ■ Crimp Terminal Specifications

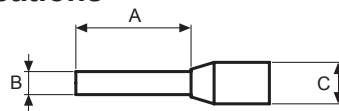

(unit: mm)

	A	B	C	Applicable wire
End Sleeve (ferrule terminal) crimp terminal	10 to 12.0	≤ 2.0	≤ 4.1	AWG22-16 (0.30 to 1.25mm <sup>2</sup> )

※ Use the UL certified crimp terminal.

### ■ Specifications

Model	ACL-20L	ACL-40L	ACL-50L	ACL-20T	ACL-40T	ACL-50T
Rated voltage	250VDC=, 250VAC~ 50/60Hz					
Rated current	≤10A					
Common type	Left +COM / Right -COM			Top +COM / Bottom -COM		
Terminal type	Screwless					
The number of terminal	20	40	50	20	40	50
Terminal pitch	5.0mm					
Applicable wires	Solid wire Ø0.6 to Ø1.25mm (60℃ only)					
	Stranded wire UL: AWG22-16 (0.30 to 1.25mm <sup>2</sup> ) (60℃ only)					
Stripped wire length	8 to 10mm					
Insulation resistance	≥1,000MΩ (at 500VDC megger)					
Dielectric strength	3,000VAC 50/60Hz for 1 minute (between open terminals)					
Vibration	Mechanical 0.75mm amplitude at frequency of 10 to 55Hz (for 1 min) in each X, Y, Z direction for 2 hours					
	Malfunction 0.75mm amplitude at frequency of 10 to 55Hz (for 1 min) in each X, Y, Z direction for 10 minutes					
Shock	Mechanical 1,000m/s <sup>2</sup> (approx. 100G) in each X, Y, Z direction for 3 times					
	Malfunction 100m/s <sup>2</sup> (approx. 10G) in each X, Y, Z direction for 3 times					
Environment	Ambient temp. -15 to 55°C, storage: -25 to 65°C					
	Ambient humi. 35 to 85%RH, storage: 35 to 85%RH					
Material	Terminal: polyamide 66, conductive plate: copper, tin plated, case: polycarbonate, base: polycarbonate					
Protection structure	IP20 (IEC standard)					
Approval	CE cUL US LISTED					
Weight <sup>*1</sup>	Approx. 71g (approx. 42g)	Approx. 146g (approx. 79g)	Approx. 164g (approx. 97g)	Approx. 71g (approx. 42g)	Approx. 146g (approx. 79g)	Approx. 164g (approx. 97g)

※1: The weight includes packaging. The weight in parenthesis is for unit only.  
 ※Environment resistance is rated at no freezing or condensation.

# Common Terminal Block

(unit: mm)

## Dimensions

### ACL-20L(T)

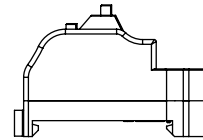
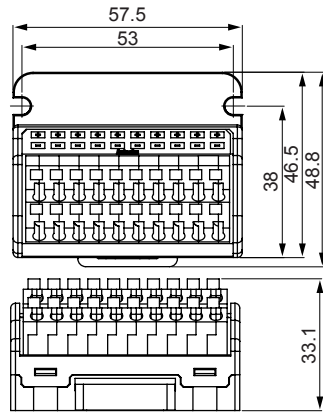

### ACL-40L(T) / ACL-50L(T)

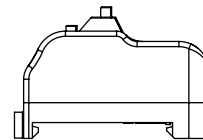
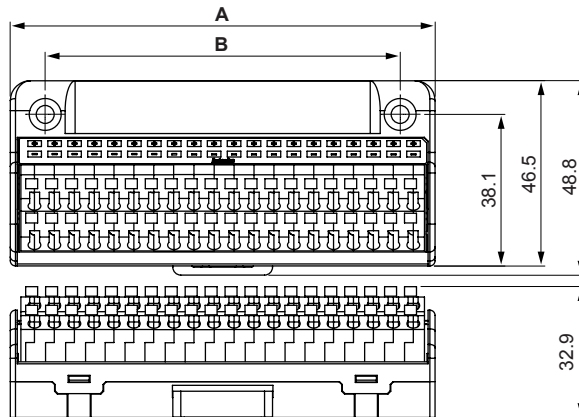

(unit: mm)

Model	A	B
ACL-40L(T)	106.5	89
ACL-50L(T)	131.5	102

## Connections

### ACL-20L

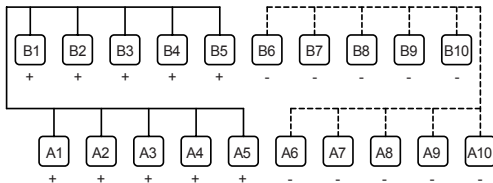

### ACL-20T

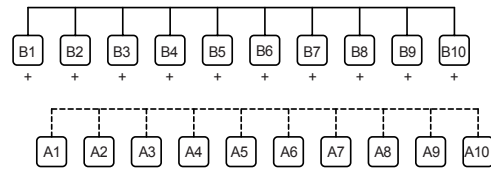

### ACL-40L

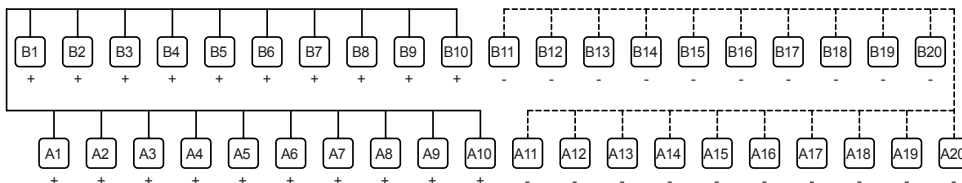

### ACL-50L

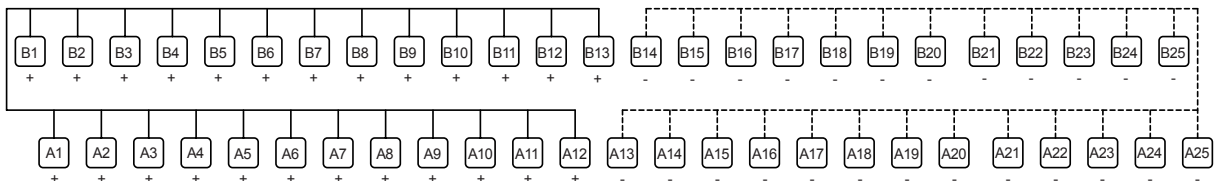

### ACL-40T / ACL-50T

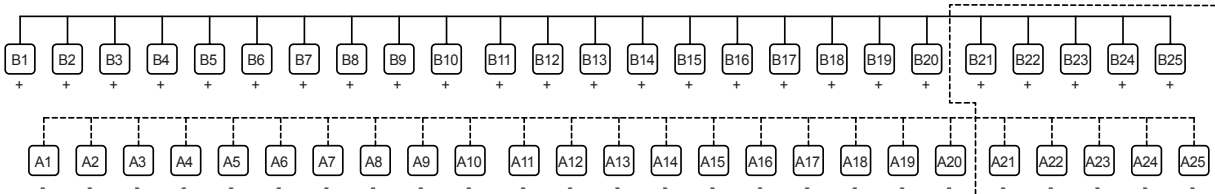

\*Dot line part is only for ACL-50T model.

I/O Terminal Blocks

Interface Terminal Blocks

Common Terminal Blocks

Sensor Connector Terminal Blocks

Relay Terminal Blocks

I/O Cables

Remote I/O

Others

ACS Series

ACL Series

ACR Series

# ACL Series

## ■ Installation

### ○ Mounting and Removing from DIN rail

#### ● Mounting

- 1) Pull the rail lock towards direction ①.
- 2) Attach the DIN rail connection part onto the DIN rail.
- 3) Push the unit towards direction ②, then push the rail lock in to lock into position.

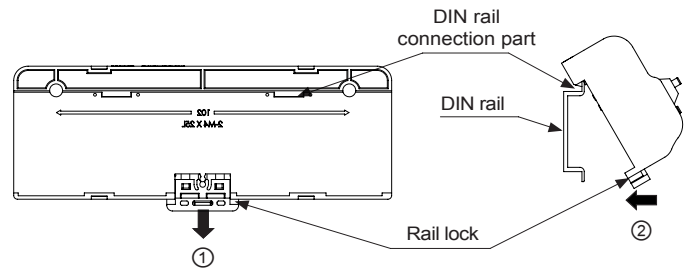

#### ● Removal

- 1) Insert a screwdriver into the rail lock hole and pull it towards direction ③.
- 2) Remove the unit by pulling the unit towards direction ④.

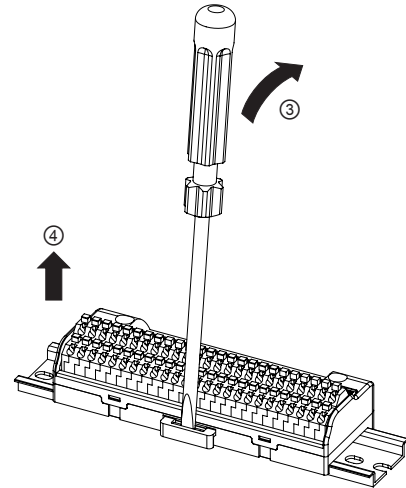

### ○ Mounting with screws

- 1) The unit can be mounted on panels using the mounting holes next to the Hirose connector.
- 2) M4×25mm spring washer screws are recommended for installation. When using flat washers, use Ø8mm diameter washers. The tightening torque should be from 0.7 to 1.0N·m.

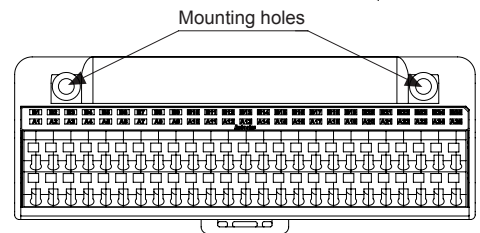

## ■ Connecting Crimp Terminals

### ○ Connecting and removing end sleeve (ferrule terminal) crimp terminal at screwless type terminal block

#### ● Connection

- 1) Push the end sleeve (ferrule terminal) crimp terminal towards direction ① to complete the connection.

#### ● Removal

- 1) Press and hold the catch above the terminal in direction ② with a flat-head screwdriver.
- 2) Pull and remove the end sleeve (ferrule terminal) crimp terminal towards direction ③.

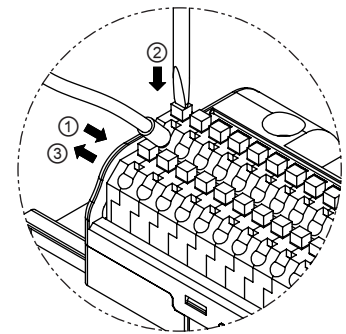

## ■ Cautions during Use

1. Follow instructions in 'Cautions during Use'. Otherwise, it may cause unexpected accidents.
2. Keep away from high voltage lines or power lines to prevent inductive noise.  
In case installing power line and input signal line closely, use line filter or varistor at power line and shielded wire at input signal line. Do not use near the equipment which generates strong magnetic force or high frequency noise.
3. This unit may be used in the following environments.
  - ① Indoors (in the environment condition rated in 'Specifications')
  - ② Altitude max. 2,000m
  - ③ Pollution degree 2
  - ④ Installation category II

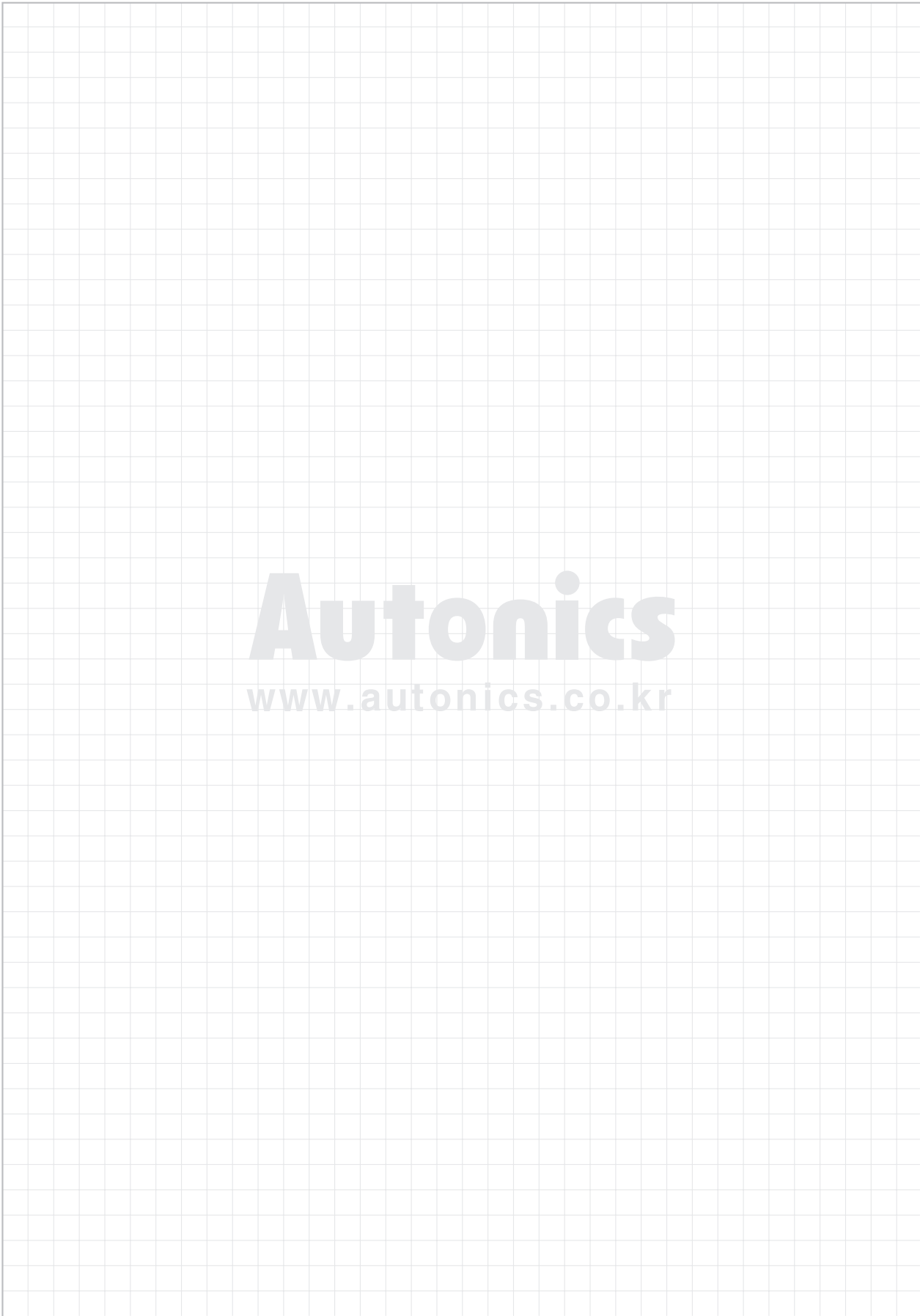

I/O Terminal Blocks

Interface Terminal Blocks

**Common Terminal Blocks**

Sensor Connector Terminal Blocks

Relay Terminal Blocks

I/O Cables

Remote I/O

Others

ACS Series

**ACL Series**

ACR Series

**Autonics**  
www.autonics.co.kr